

#4 [K13] TIES, SPACING VARIES. SEE TABLE ON SHEET S-5 FOR TIE SPACING & QUANTITIES.

(8) M33 [1 1/4" ϕ] ANCHOR BOLTS ON A 19" ϕ [482.6mm ϕ] BOLT CIRCLE.

VERTICAL BARS EQ. SPACED RADIALLY. (14)- #8 [k25] FOR 3'-0" [915mm] ϕ PIER.

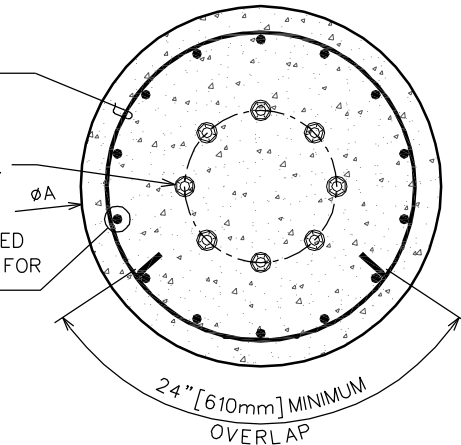

SECTION B-B

SCALE: N.T.S.

NOTES:

1. THIS DRAWING DOES NOT REPRESENT THE ACTUAL FOUNDATION, IT IS FOR REFERENCE ONLY. SEE SHEET S-5 FOR DIMENSIONS AND REINFORCEMENT QUANTITIES.
2. TOWER GROUNDING SHALL BE PERFORMED IN ACCORDANCE WITH NEC REQUIREMENTS.
3. CONDUIT PLACEMENT SHALL BE PLACED IN ACCORDANCE WITH BOTH THE NEC AND SOUTHWEST WINDPOWER REQUIREMENTS.
4. THE FOUNDATION DESIGNS ARE BASED ON THE SOIL INFORMATION LISTED IN TABLE 1804.2/1806.2 (IBC 2006/2009) REFERENCED ON SHEET S-1. IT IS THE RESPONSIBILITY OF THE OWNER TO VERIFY BY GEOTECHNICAL INVESTIGATION THAT ACTUAL SITE SOIL PARAMETERS EQUAL OR EXCEED THOSE SHOWN IN THE REFERENCED TABLE. IF CONDITIONS OTHER THAN THOSE DESCRIBED IN THE REFERENCED TABLE ARE ENCOUNTERED A FOUNDATION ANALYSIS SHOULD BE PERFORMED TO DETERMINE THE STRUCTURAL ADEQUACY OF THE SUBSTRUCTURE.

SEAL:



Expires 09/30/2014

November 29, 2011

FOUNDATION ALTERNATIVE - PIER

SCALE: N.T.S.

TOWER ENGINEERING PROFESSIONALS
 3703 JUNCTION BOULEVARD
 RALEIGH, NC 27603-5263
 (919) 661-6351

PROJECT INFORMATION:
**45-FT [13.7M]
 MONOPOLE (45-19)
 FOUNDATIONS**
 Skystream 3.7

SOUTHWEST WINDPOWER
 1801 West Route 66
 Flagstaff, AZ 86001
 Office: (928) 779-9463
www.windenergy.com

REV	DATE
4	11-29-2011
3	04-07-2011
2	03-15-2011
1	07-20-2010

DRAWN BY: LSB CHECKED BY: REG

SHEET NUMBER: S-4	REVISION: 4
TEP#: 110002.08	

45-FT [13.7M] MONOPOLE (45-19) FOUNDATION DIMENSIONS - PIER

ZONE	SOIL CLASS	DIMENSION		VERTICAL REINF.		TIE SPACING		#4 [K13] TIE QUANTITY
		A	B	SIZE	QTY.	SP1	SP2	
2	3	3'-0" [915mm]	10'-0" [3048mm]	#8 [K25]	14	6"± [150mm] O.C.	12"± [300mm] O.C.	20
	4	3'-0" [915mm]	11'-0" [3353mm]	#8 [K25]	14	6"± [150mm] O.C.	12"± [300mm] O.C.	22
	5	3'-0" [915mm]	13'-0" [3962mm]	#8 [K25]	14	6"± [150mm] O.C.	12"± [300mm] O.C.	26
ZONE	SOIL CLASS	DIMENSION		VERTICAL REINF.		TIE SPACING		#4 [K13] TIE QUANTITY
		A	B	SIZE	QTY.	SP1	SP2	
3	3	3'-0" [915mm]	8'-6" [2591mm]	#8 [K25]	14	6"± [150mm] O.C.	12"± [300mm] O.C.	17
	4	3'-0" [915mm]	9'-0" [2743mm]	#8 [K25]	14	6"± [150mm] O.C.	12"± [300mm] O.C.	18
	5	3'-0" [915mm]	10'-6" [3200mm]	#8 [K25]	14	6"± [150mm] O.C.	12"± [300mm] O.C.	21

SEAL:



Expires 09/30/2014

November 29, 2011



TOWER ENGINEERING PROFESSIONALS
3703 JUNCTION BOULEVARD
RALEIGH, NC 27603-5263
(919) 661-6351

PROJECT INFORMATION:

**45-FT [13.7M]
MONOPOLE (45-19)
FOUNDATIONS**
Skystream 3.7

**SOUTHWEST
WINDPOWER**
1801 West Route 66
Flagstaff, AZ 86001
Office: (928) 779-9463
www.windenergy.com

4	11-29-2011
3	04-07-2011
2	03-15-2011
1	07-20-2010
REV	DATE

DRAWN BY: LSB CHECKED BY: REG

SHEET NUMBER:

S-5

REVISION:

4

TEP#: 110002.08